



# ADAMANT 82000-82010

FIRE EXTINGUISHER CABINET 6/9 kg



**External dimensions (mm):** 675x310x250

**Internal Dimensions (mm):** 612x229x150

**Weight (kg):** 4.0

**Ring Diameter (mm):** 150/170 e 170/190

**Quantity per pallet (n°):** 54

**Pallets dimensions (cm):** 143x99x266

**Pallet Weight (kg):** 255

## COMPONENTS

- Resin label
- Inspection window in polycarbonate
- Nylon clamping ring with PVC spring
- Double handles in Nylon
- Internal EPDM seal

## TECHNICAL FEATURES

**Material:** polypropylene, nylon, polycarbonate

**Production Process:** Injection Molding

Label with company logo

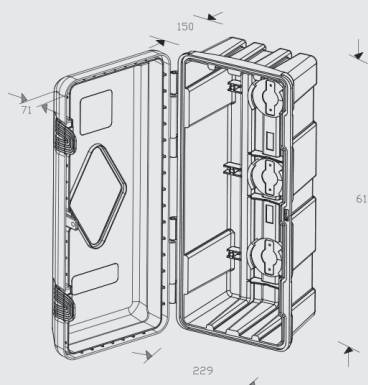
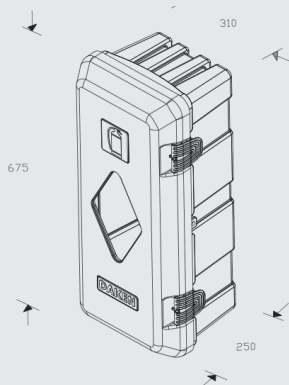

## TEST AND CERTIFICATIONS

• TÜV RHEINLAND (4/2010):

**Flammability:** Flame Speed (Renault D451333)

**Weather resistance:** for dust and water (DIN 40050-9) IP59K

**Resistance** to hydrocarbons and to lubricating oils (ECE R3)

**Ageing:** accelerated UV test (ISO 4892-2)

**Compression:** 1200 kg at various temperatures

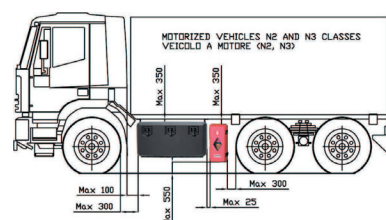

• TÜV RHEINLAND or side protection (conformity to EU Directives 89/297 / EEC and ECE Reg. N. 73)

## PRODUCT FEATURES

- 1 Double ergonomic handles in Nylon
- 2 Inspection window with "OR" seal
- 3 Lockable against burglary or mishandling
- 4 Nylon pins for lid-body hinges
- 5 Extinguisher holding kit composed of: PVC clamping spring with 4 holes, and Nylon clamping ring available in two sizes
- 6 Grey internal Seal in EPDM
- 7 Bayonet cap for clamping ring
- 8 Reinforced fixing points



## OPTIONALS

**Brackets:** 88040, 88041, 88042

**Options:** Custom resin labels (pictogram and logo)

**SPARE PARTS:** 89505, 89507, 89506, 89508, 89504