



JUST 81106

TOOL BOX 750



External dimensions (mm): 750x350x450

Weight (kg): 5,20

Optimal load (kg): 45

Capacity (lt): 65

Quantity per pallet (n°): 15

Pallets dimensions (cm): 108x76x250

Pallet Weight (kg): 100

TECHNICAL FEATURES

Material: polypropylene

Production Process: Injection Molding

Label with company logo

COMPONENTS

- Nylon handle
- EPDM seal

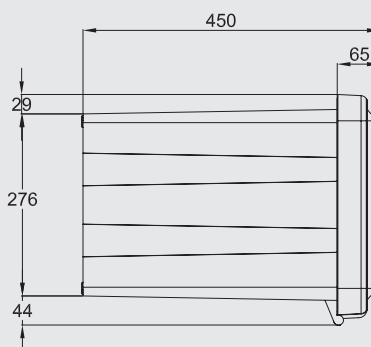
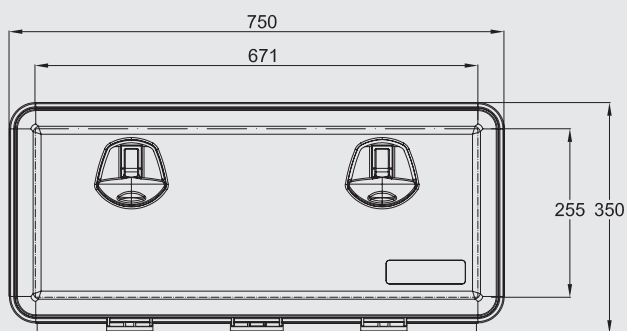

PRODUCT FEATURES

- 1 The reinforced lid with grid structure minimizes lid deformations. It also guarantees the maximum resistance to the possible breakage due to the collision of the objects inside the box.
- 2 The innovative compression locking system with a hook guarantees perfect cohesion between body and lid. The handle is equipped with a cylinder lock and 2 keys.
- 3 The internal EPDM seal prevents dust and water ingress.
- 4 The reduced thickness of the plastic is compensated by the internal reinforcement ribs, suitable as shelf runners.
- 5 The fast body-lid fixing with 4 contact points guarantees fast assembling and reliability in everyday use.



OPTIONALS

VERTICAL BRACKETS: 88120; 88121

HORIZONTAL BRACKETS: 88131