



WELVET 81009

TOOL BOX 1250 mm



External dimensions (mm): 1250x524x500

Weight (kg): 15.50

Optimal load with vertical and horizontal brackets (kg): 75

Optimal load with U-brackets (kg): 115

Capacity (lt): 190

Quantity per pallet (n°): 8

Pallets dimensions (cm): 126x108x225

Pallet Weight (kg): 144

TECHNICAL FEATURES

Material: polypropylene

Production process: Injection Molding

Label with company logo

COMPONENTS

- Nylon handle
- EPDM seal
- Europlex lock (European Patent EP 1442845)

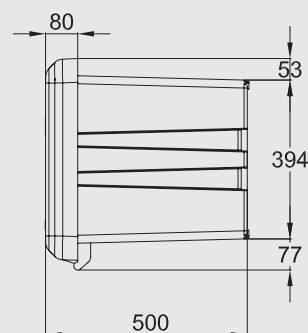
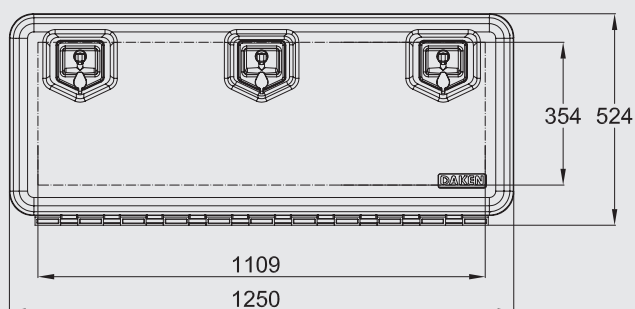

PRODUCT FEATURES

- 1 Europlex lock with cylinder
- 2 The Innovative compression locking system with a hook guarantees perfect cohesion between body and lid
- 3 Body-lid fixing system with 10 contact points which guarantees fast assembling and reliability in everyday use
- 4 Body with reinforcement ribs
- 5 Reinforced lid
- 6 Available with internal shelves



OPTIONALS

VERTICAL BRACKETS: 88020,88120,88220

HORIZONTAL BRACKETS: 88030,88130,88230

U-BRACKETS (to combine with vertical or horizontal brackets): 88050, 88051

SPARE PARTS: 89010, 89501, 89503

OPTIONS: Resin label, Serigraphed logo, Shelves