



JUST 81104

TOOL BOX 600



External dimensions (mm): 600x415x460

Weight (kg): 4.9

Optimal load (kg): 45

Capacity (lt): 71.5

Quantity per pallet (n°): 25

Pallets dimensions (cm): 124x100x255

Pallet Weight (kg): 150

TECHNICAL FEATURES

Material: polypropylene

Production Process: Injection Molding

Label with company logo

COMPONENTS

- Nylon handle
- EPDM seal

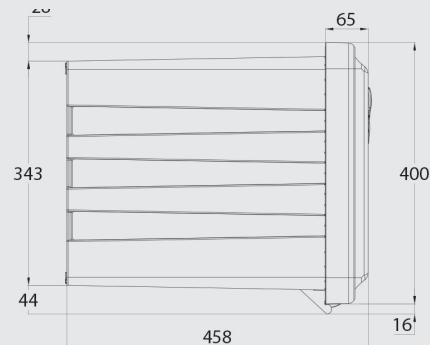
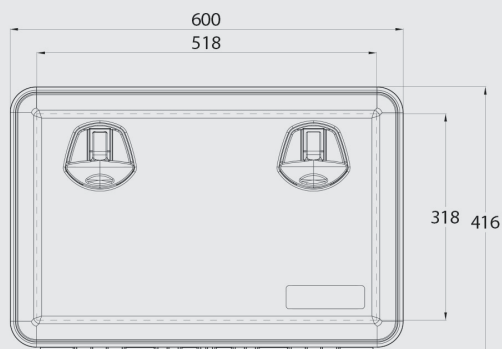

PRODUCT FEATURES

- 1 The reinforced lid with grid structure minimizes lid deformations. It also guarantees the maximum resistance to the possible breakage due to the collision of the objects inside the box
- 2 The innovative compression locking system with a hook guarantees perfect cohesion between body and lid. The handle is equipped with a cylinder lock and 2 keys
- 3 The internal EPDM seal prevents dust and water ingress
- 4 The reduced thickness of the plastic is compensated by the internal reinforcement ribs, suitable as shelf runners
- 5 The fast body-lid fixing (3 contact points for 81100 and 5 contact points for 81104), guarantees fast assembling and reliability in everyday use



OPTIONALS

VERTICAL BRACKETS: 88120, 88121

HORIZONTAL BRACKETS: 88131