



# WELVET 81006

TOOL BOX 800 mm



**External dimensions (mm):** 830x500x470  
**Weight (kg):** 10.5  
**Optimal load (kg):** 65  
**Capacity (lt):** 119

**Quantity per pallet (n°):** 10  
**Pallets dimensions (cm):** 105x85x265  
**Pallet Weight (kg):** 130

## TECHNICAL FEATURES

**Material:** polypropylene  
**Production Process:** Injection Molding  
Label with company logo

## COMPONENTS

- Nylon handle
- EPDM seal
- Europlex lock (European Patent EP 1442845)

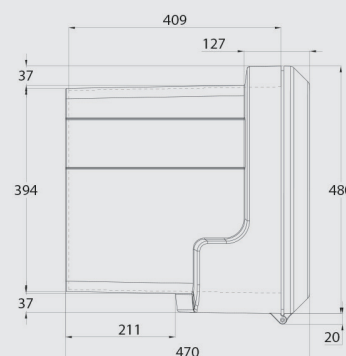

## TEST AND CERTIFICATIONS

- **FEM method:** Result of the test load resistance conducted with simulation software  
Applied load: 1600 N  
Tensione max (stress): 12.89 MPa, (Limite Von Mises 22 MPa)  
max deformation: 9.04 mm  
Optimal load: 650 N

- **IP TEST** (TÜV Rheinland 7/2012)

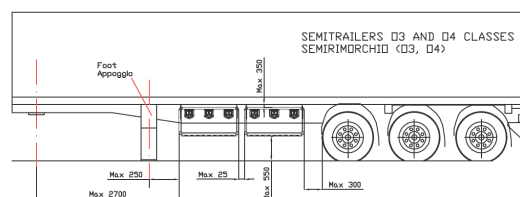

- **TÜV RHEINLAND** or side protection (conformity to EU Directives 89/297 / EEC and ECE Reg. N. 73)

## PRODUCT FEATURES

- 1 Europlex lock with cylinder
- 2 Compression locking system with rubber seal
- 3 The continuous contact points between body and lid
- 4 The Reinforced body guarantees maximum load avoiding "U" bracket mounting
- 5 Smooth internal surface
- 6 reinforced lid



## OPTIONALS

**VERTICAL BRACKETS:** 88020, 88120, 88220  
**HORIZONTAL BRACKETS:** 88030, 88130, 88230

**SPARE PARTS:** 89010, 89501, 89503, 89502  
**OPTIONS:** Resin label, Serigraphed logo, shelves, gas spring, chain